

## Movement Control Joints

### Introduction

The Fall 2002 Issue of *"Masonry Chronicles"* discussed shrinkage cracks in details and various ways to reduce them. This issue further discusses the "movement control" in concrete masonry and should be considered as a continuation of the shrinkage issue.

It is erroneous to assume that by simply specifying Type I (moisture controlled) units, one can eliminate shrinkage crack problems.

First of all, ASTM C90 has eliminated Type I and Type II Units for several reasons stated below:

Moisture content in the unit alone is not responsible for potential cracking. Type I units were also required to be protected until placed in the wall, which is difficult to control.

The outside conditions (temperature, humidity and wind) also impact the moisture content of the units and shrinkage potential.

The linear drying shrinkage is still limited to 0.00065 in/in tested according to ASTM C426. Since this is a laboratory determined drying shrinkage at saturated condition, this number should not be used to determine drying shrinkage in the field. Depending upon particular climatic conditions, 50 to 70% of this value is a reasonable assumption. Thus, for a 50 foot-long wall, the drying shrinkage potential is in the range of 0.19 inches to 0.273 inches. Control joints can be provided to accommodate this change in length.

### Control Joints - Basics

A control joint by its very definition is a clear vertical separation between two adjacent wall segments. The joint must allow free movement of wall segments.

- Control joints should be placed where the wall mass or geometry changes occur. (See Figures 1 and 2)
- Control joints should extend through the entire thickness of the wall. (See Figure 3)
- Horizontal reinforcement in the wall should stop at each side of the joint, except in bond beams at floor and roof levels, which are required to transfer forces from diaphragms to walls. (See Figure 4)
- Dowels or shear keys across the joint may be provided to transfer out-of-plane loads so long as they do not restrict the movement in the plane of the wall. (See Figure 5)

Control joint details are available from CMACN ("Typical Masonry Details").

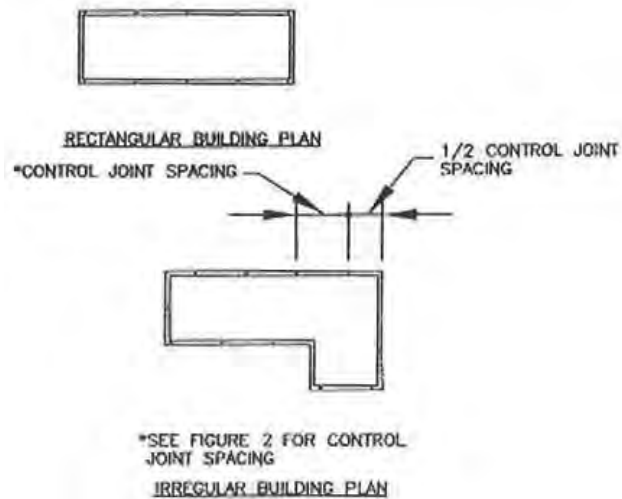

**Figure 1: Suggested Control Joint Locations**

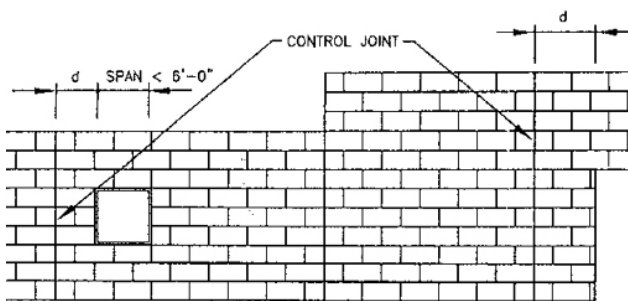

**Figure 2: Suggested Locations and Spacing For Control Joints in CMU Walls**

### Design for Movement Control

In California, the majority of structural concrete masonry walls are fully grouted; thus the shrinkage calculations are more complex as compared to ungrouted walls.

The linear drying shrinkage of units, along with strength and ingredients of grout acting together, makes calculations not only tedious, but also with lesser degree of reliability.

Under the most ideal assumption of all components (units, mortar and grout) behaving as a unit, it is possible to calculate strains in masonry and design horizontal reinforcement to limit crack widths to less than 0.020 inches (a number considered acceptable for long-term behavior of wall). However, such calculations are based on the tensile strength of mortar, grout and units, which are not only different, but also have a high degree of variability. (A typical value for tensile strength of masonry units is 200 psi, whereas that of a head joint is 25 psi. Taking an average of two values is questionable, although simple.)

To resist seismic shear, considerable amount of horizontal reinforcement is provided in concrete masonry walls. Such reinforcement resists shrinkage, however, one needs to use judgment. If the reinforcement is stretched to prevent shrinkage cracks, sufficient capacity may not be available to resist seismic shear.

Due to the uncertainties associated with the calculations of reinforcement for shrinkage resistance, it is perhaps desirable to use an empirical approach to provide control joints.

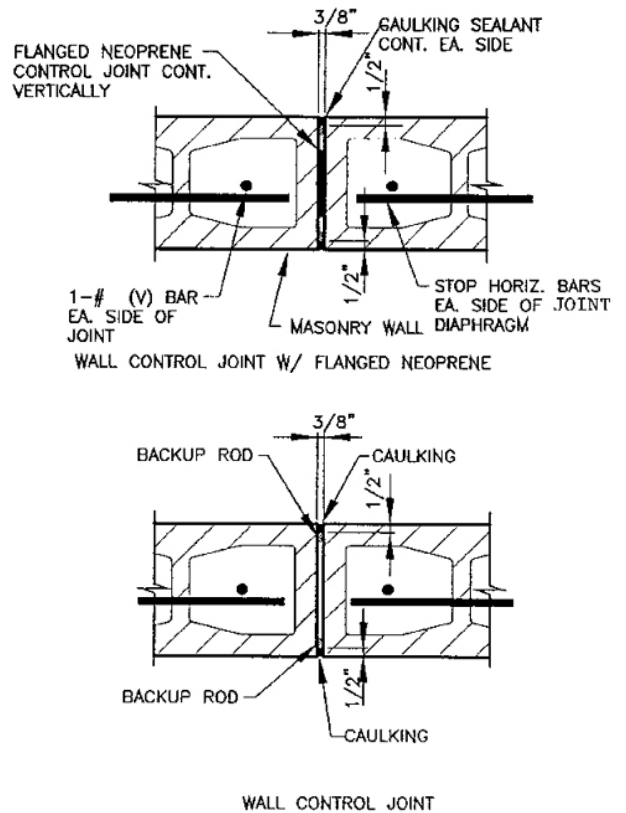

**Figure 3: Masonry Control Joint Details**

## Empirical Design (UBC and NCMA Comparisons)

Based upon the historical data over many years in different geographical conditions, National Concrete Masonry Association (NCMA) has developed the following criteria for control joints.

The Spacing of control joints should be the lesser of:

- a. 25 feet or
- b. Length to height ratio of 1.5

If a wall were 22 feet high, the governing spacing would be 25 feet, since based upon "b," the spacing would be 33 feet.

The empirical criteria is based upon assumption of minimum horizontal reinforcement of  $0.025 \text{ in}^2/\text{ft}$  height of the wall.

If we consider a typical 8-inch thick concrete masonry wall and provided horizontal reinforcement spaced at 48 inches, the required area would be  $4 \times 0.025 = 0.10 \text{ in}^2$ . Thus, for shrinkage control only, we need to provide  $2\frac{1}{4}$  diameter wires in the mortar joint. However, in California, based on the 1997 UBC, the minimum horizontal reinforcement requirement is  $0.0007 \text{ bt.}$  and the minimum size of reinforcement is #3 (except that joint reinforcement can be smaller). The spacing of bars cannot exceed 48 inches. Whereas the minimum horizontal reinforcement requirement in the UBC is based upon the volume of masonry, NCMA empirical requirements are not based upon the total volume, since most of the country uses ungrouted masonry.

Perhaps, in ungrouted masonry, surface area is more relevant as compared to volume.

The following table compares minimum required horizontal reinforcement per UBC provisions and NCMA TEK 10-2B for 48 inch spacing.

**Table 1**

Wall Thickness inches (actual)	$A_s(\text{in}^2/\text{ft})$ ( $0.0007 \text{ bt.}$ )	UBC	NCMA
6 (5.625)	0.047	0.188	0.10
8 (7.625)	0.064	0.256	0.10
10 (9.625)	0.081	0.324	0.10
12 (11.625)	0.098	0.392	0.10

It is clear from a quick review of the table that minimum UBC requirements for horizontal steel exceed those required to control shrinkage cracks.

In projects where minimum horizontal reinforcement requirement governs, the shrinkage control requirement needs are already met.

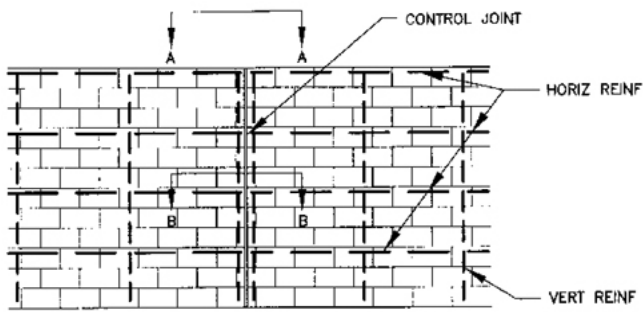

**ELEVATION OF MASONRY WALL WITH CONTROL JOINT**

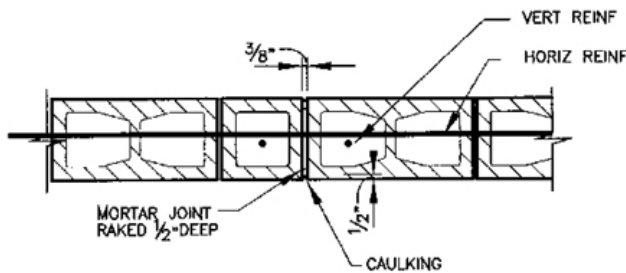

**SECTION A-A**  
HORIZ REINF CONTINUOUS THROUGH JOINT ONLY AT LEDGER OR LINTEL

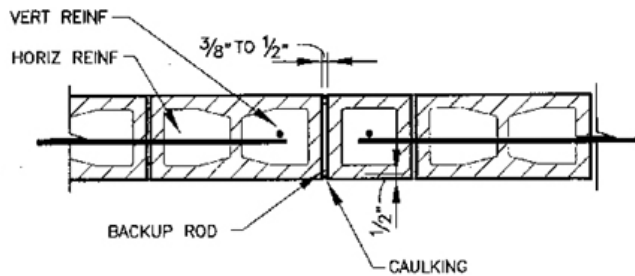

**SECTION B-B**  
HORIZ REINF DOES NOT CROSS JOINT

**Figure 4: Control Joint Elevation and Plan**

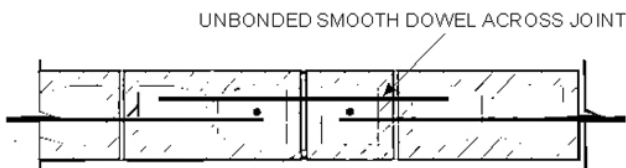

**Figure 5: . Dowel Across Joint**

## Horizontal Reinforcement

The following approach is suggested to compute total horizontal reinforcement needed.

- Add 0.025 in<sup>2</sup>/ft to that required by design. If the ratio is still below 0.0007 bt., use the minimum required. If the ratio is more than 0.0007 bt. use that ratio, however for total reinforcement requirement in the wall, deduct only 0.0007 bt.

The following example hopefully will clarify the approach.

Consider an 8-inch nominally thick, fully grouted wall. Horizontal reinforcement required for shear, calculated separately = 0.0006 bt.

$$\begin{aligned} &= 0.0006 (12) (7.625) \\ &= 0.055 \text{ in}^2/\text{ft} \end{aligned}$$

Total steel ratio required per Code = 0.002 bt.

Add shrinkage steel component = 0.025 in<sup>2</sup>/ft  
Total horizontal steel required = 0.080 in<sup>2</sup>/ft (0.00087 bt.)  
Balance required vertical steel = (0.002 - 0.0007) bt.  
= 0.0013 bt. = 0.0013 (12) (7.625) = 0.12 in<sup>2</sup>/ft

Deduct only 0.0007 bt. from 0.002 bt to calculate remaining vertical steel.

Provide 2 #3 horizontal @ 32 inches on center and provided #5 @ 40 inches on center vertically.

## Conclusions

1. Specifying locations of control joints in a concrete masonry building requires engineering judgement.
2. Spacing of control joints may be determined empirically. These criteria are based upon a lot of experience in various geographical locations.
3. Calculating reinforcement requirements to prevent shrinkage cracks without adequate attention to spacing of control joints has a lot of uncertainty associated with it.
4. Shrinkage cracks in masonry is a result of poor design and lack of attention to control joints. A properly designed wall will result in acceptable minor cracks like all materials with cement in them.

This issue is complimentary to the "Fall 2002 Masonry Chronicles" issue on shrinkage of concrete masonry.

*This issue of "Masonry Chronicles" was written by Dr. Vilas Mujumdar, Executive Director of Concrete Masonry Association of California and Nevada.*

*"Masonry Chronicles" is a publication of the Concrete Masonry Association of California and Nevada.*

***Reproduction is expressly prohibited without written permission from CMACN.***

*Please contact the Association Executive Director, Dr. Vilas Mujumdar, with any comments or suggestions for future issues.*

Additional "Masonry Chronicles" may also be seen on the CMACN website at <http://www.cmacn.org>

## CMACN ACTIVE MEMBERS

Active Members are an individual, partnership, or corporation which is actively engaged in the manufacture and sale of concrete masonry units.

- ◆ Angelus Block Company, Inc.
- ◆ Basalite
- ◆ Blocklite
- ◆ Calstone
- ◆ Crystalite Block Corporation

- ◆ Desert Block Co., Inc.
- ◆ McNear Brick & Block
- ◆ ORCO Block Co., Inc.
- ◆ RCP Block & Brick, Inc.
- ◆ Valley Block Company